

# CMV/CES 12 & 60 Series

0–12,000 psi & 0–6000 psi DYNAFLOW® Pneumatically Operated Patented Shutoff Valves



## Features

- Zero leakage
- Three operating modes
- Bi-directional
- Positive spindle retention
- Extended stem for extreme temperatures
- Field tested at  $1 \times 10^{-7}$  torr to 12,000 psi with zero leakage

## Technical Data

<b>Body Construction Materials</b>	<ul style="list-style-type: none"> <li>• Valve body: 303 or 316 stainless steel</li> <li>• Actuator body: aluminum</li> </ul>
<b>Seat &amp; Packing Material</b>	Teflon®
<b>Operating Pressures</b>	<ul style="list-style-type: none"> <li>• CMV12 &amp; CES12: 0 to 12,000 psi (828 bar)</li> <li>• CMV60 &amp; CES60: 0 to 6000 psi (414 bar)</li> </ul>
<b>Proof Pressures</b>	<ul style="list-style-type: none"> <li>• CMV12 &amp; CES12: 18,000 psi (1,241 bar)</li> <li>• CMV60 &amp; CES60: 9000 psi (621 bar)</li> </ul>
<b>Burst Pressures</b>	<ul style="list-style-type: none"> <li>• CMV12 &amp; CES12: 48,000 psi (3,310 bar) minimum</li> <li>• CMV60 &amp; CES60: 24,000 psi (1,655 bar) minimum</li> </ul>
<b>Operating Temperatures</b>	<ul style="list-style-type: none"> <li>• CMV12 &amp; CMV60: –65° F to +250° F (–54° C to +121° C)</li> <li>• CES12 &amp; CES60: –452° F to +450° F (–269° C to +232° C)</li> </ul>
<b>Connection Sizes</b>	3/8"–1"
<b>Cylinder Air Service:</b>	<ul style="list-style-type: none"> <li>• Operating pressure: 50 to 150 psig (3 to 10 bar)</li> <li>• Proof pressure: 225 psig (16 bar)</li> <li>• Burst pressure: 600 psig (41 bar)</li> </ul>
<b>Leakage</b>	All series and actuators: bubble-tight

Note: Proper filtration is recommended to prevent damage to sealing surface.

## How it Works

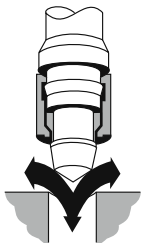

### Full Open

The relaxed Teflon® is fully contained. With no obstructions, the stem develops full hole diameter for high Cv. The body can be in-line welded without being disassembled or requiring weld-neck extensions.

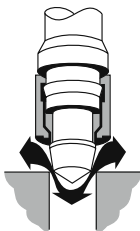

### Throttling

By advancing the stem inward, the valve takes a configuration identical to a needle or tapered plug-type valve and offers comparable control. Soft seat valves are not usually capable of enduring high pressure drop in this mode of operation as their seat faces wire-draw, erodes, or reverse pressure drop blows the seal out. DYNAFLOW® valves give you trouble-free throttling.

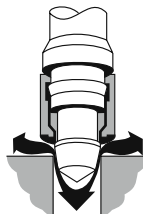

### Metering

By advancing the throttling configuration inwardly, the valve now offers a type of metering not common to either hard or soft seat valves. Precision fitted internal diameters give you this excellent metering control. The seat is fully contained and is protected from the effects of erosion, washout, nibbling or surge.

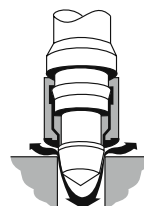

### Ultra-fine Metering

As the inward motion continues, the clearance between the tapered end of the spindle and the body seat is further reduced; the space between the seat housing and the flat body seat may be infinitely restricted to provide ultra-fine metering.

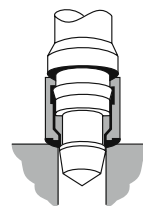

### Final Absolute Shutoff

During final closing, the Teflon® seat is mechanically compressed by relative motion between the spindle and the seal housing. The seat becomes elastic and conforms to the sealing area regardless of the line pressure. Since the seat is pressurized independent of line pressure, it remains absolute under all conditions. The process is reversible, since the seat is elastic under pressure and returns into its encapsulated state as mechanical compression is relaxed.

Shutoff valves

## Circle Seal Controls

2301 Wardlow Circle • Corona, CA 92880  
 Phone (951) 270-6200 • Fax (951) 270-6201  
 www.circle-seal.com

# CMV/CES 12 & 60 Series

## Dimensions—CMV Series DYNAFLOW® Valves

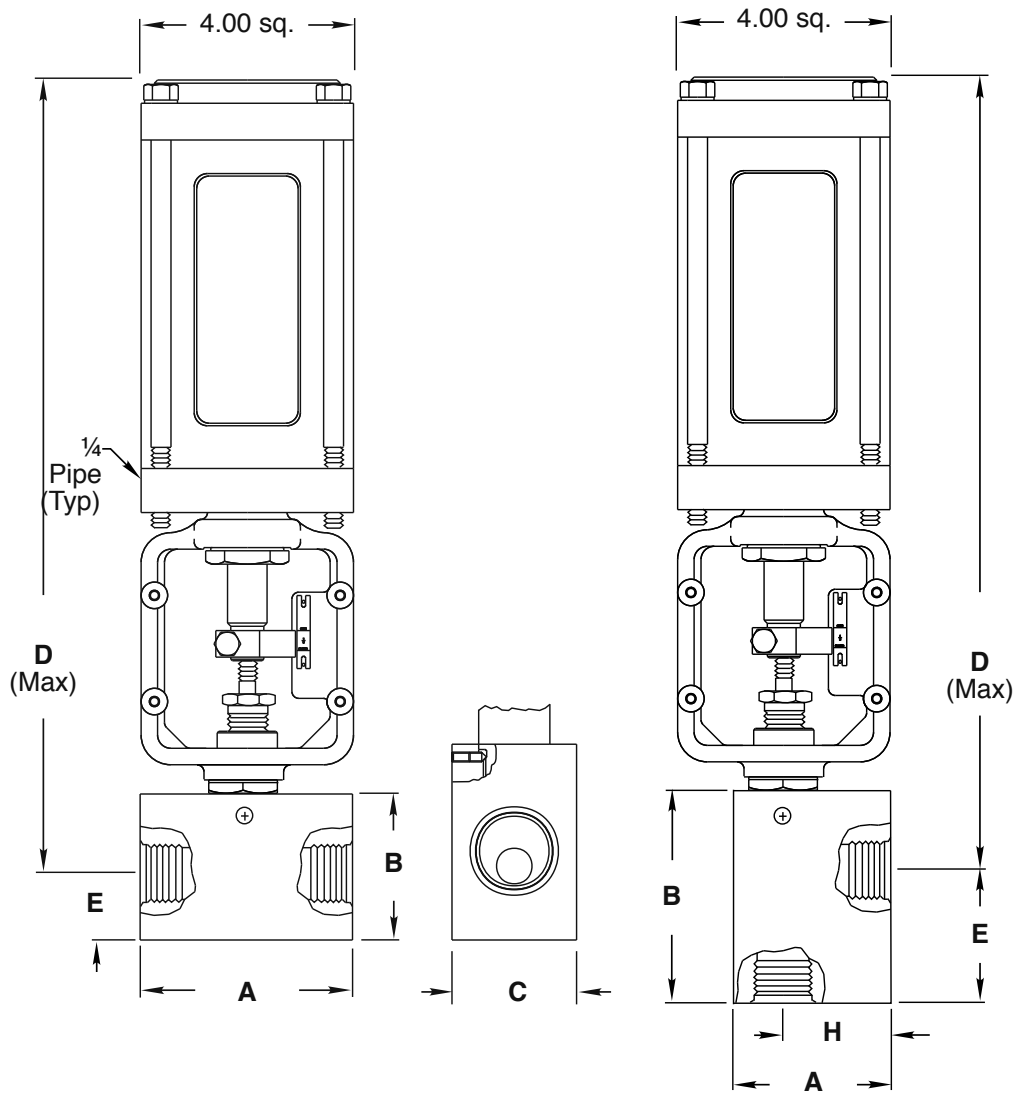

### Globe Dimensions (inches): CMV60 & CMV12 Series

Port	A	B		C		D	E		Cv**
		CMV60	CMV12	CMV60	CMV12		CMV60	CMV12	
3/8"	3.00	2.00	2.25	1.25	1.75	14.90	0.80	1.05	1.7
1/2"	3.00	2.00	2.25	1.25	1.75	14.90	0.80	1.05	1.7
9/16"*	4.00	2.75	3.00	1.75	2.75	15.70	1.10	1.35	1.7
3/4"	4.00	2.75	3.00	1.75	2.75	15.70	1.19	1.44	5.6
1"	4.00	2.75	3.00	1.75	2.75	15.70	1.19	1.44	5.6

### Angle Dimensions (inches): CRMV60 & CRMV12 Series

Port	A		B	C		D	E		H	Cv**
	CRMV60	CRMV12		CRMV60	CRMV12		CRMV60	CRMV12		
3/8"	2.00	2.25	3.00	1.25	1.75	14.90	1.80	1.98	1.43	1.7
1/2"	2.00	2.25	3.00	1.25	1.75	14.90	1.80	1.98	1.43	1.7
9/16"*	2.75	3.00	4.00	1.75	2.75	15.50	2.90	2.90	1.87	1.7
3/4"	2.75	3.00	4.00	1.75	2.75	15.50	2.50	2.50	1.87	5.6
1"	2.75	3.00	4.00	1.75	2.75	15.50	2.50	2.50	1.87	5.6

\* In Aminco™ end fittings only.

\*\* Cv based on female pipe ends.

# CMV/CES 12 & 60 Series

## Dimensions—CES Series DYNAFLOW® Valves

**Extended Stem for Extreme Service: –452° F to +450° F (–269° C to +232° C)**

The basic valve body, seating configuration, stem packing and body parts are identical to the CMV Series. However, the CES Series utilizes a long cylindrical barrel and stem to insulate the stem packing area from the line fluid. The extended barrel and stem provide ample heat dispersion so the valve can be operated even though the fluid passing through the main portion of the valve may be at extreme temperatures.

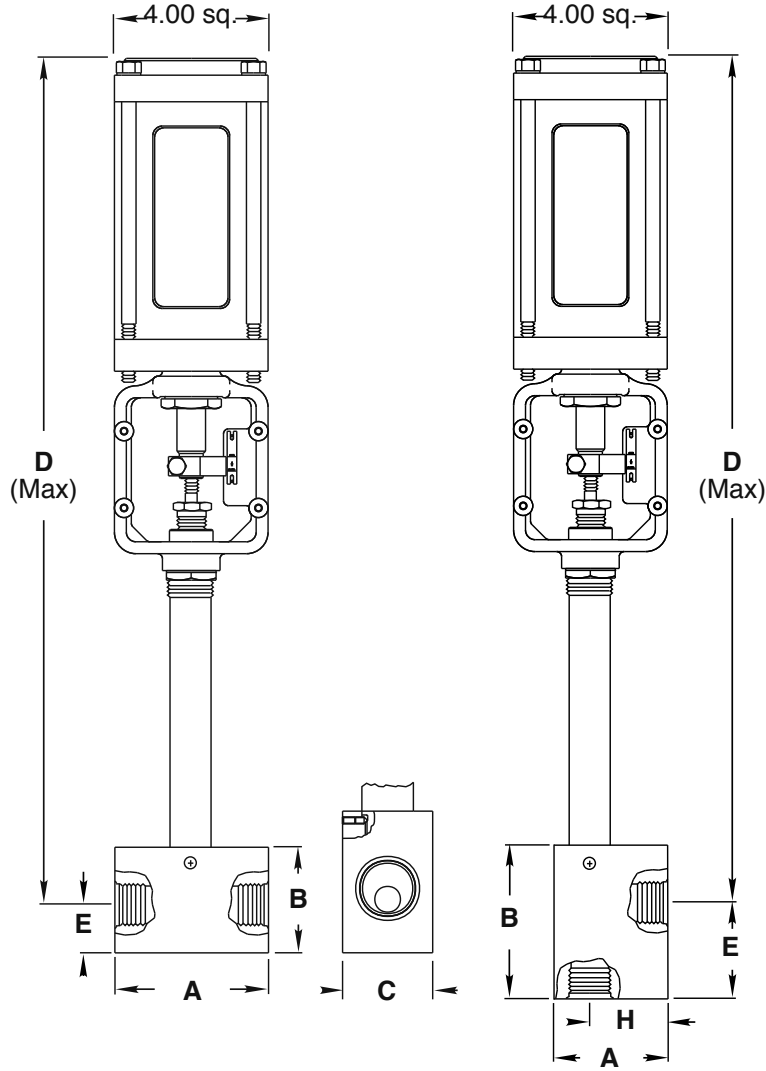

### Globe Dimensions (inches): CES60 & CES12 Series

Port	A	B		C		D	E		Cv**
		CES60	CES12	CES60	CES12		CES60	CES12	
3/8"	3.00	2.00	2.25	1.25	1.75	20.87	0.80	1.05	1.7
1/2"	3.00	2.00	2.25	1.25	1.75	20.87	0.80	1.05	1.7
9/16"*	4.00	2.75	3.00	1.75	2.75	21.20	1.19	1.35	1.7
3/4"	4.00	2.75	3.00	1.75	2.75	21.20	1.19	1.44	5.6
1"	4.00	2.75	3.00	1.75	2.75	21.20	1.19	1.44	5.6

### Angle Dimensions (inches): CRES60 & CRES12 Series

Port	A		B	C		D	E		H	Cv**
	CRES60	CRES12		CRES60	CRES12		CRES60	CRES12		
3/8"	2.00	2.25	3.00	1.25	1.75	20.65	1.80	1.98	1.43	1.7
1/2"	2.00	2.25	3.00	1.25	1.75	20.65	1.80	1.98	1.43	1.7
9/16"*	2.75	3.00	4.00	1.75	2.75	21.05	2.50	2.90	1.87	1.7
3/4"	2.75	3.00	4.00	1.75	2.75	21.05	2.50	2.50	1.87	5.6
1"	2.75	3.00	4.00	1.75	2.75	21.05	2.50	2.50	1.87	5.6

\* In Aminco™ end fittings only.

\*\* Cv based on female pipe ends.

# CMV/CES 12 & 60 Series

## How to Order

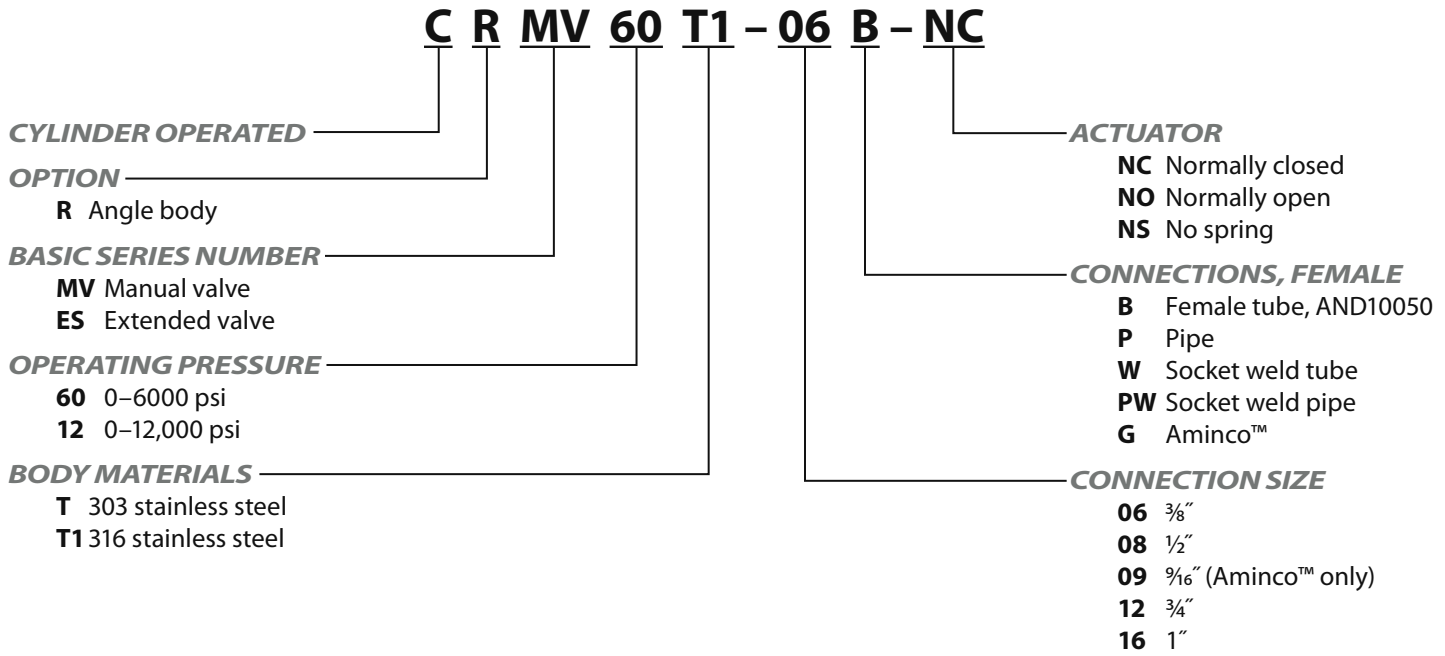

Please consult your Circle Seal Controls distributor or the factory for information on special connections, operating pressures and temperature ranges.

### Repair Kits

In normal service, the only part(s) which may require replacement is(are) the seal(s). A repair kit may be ordered by placing a "K/" in front of the complete part number (i.e. K/MV12T-06B).

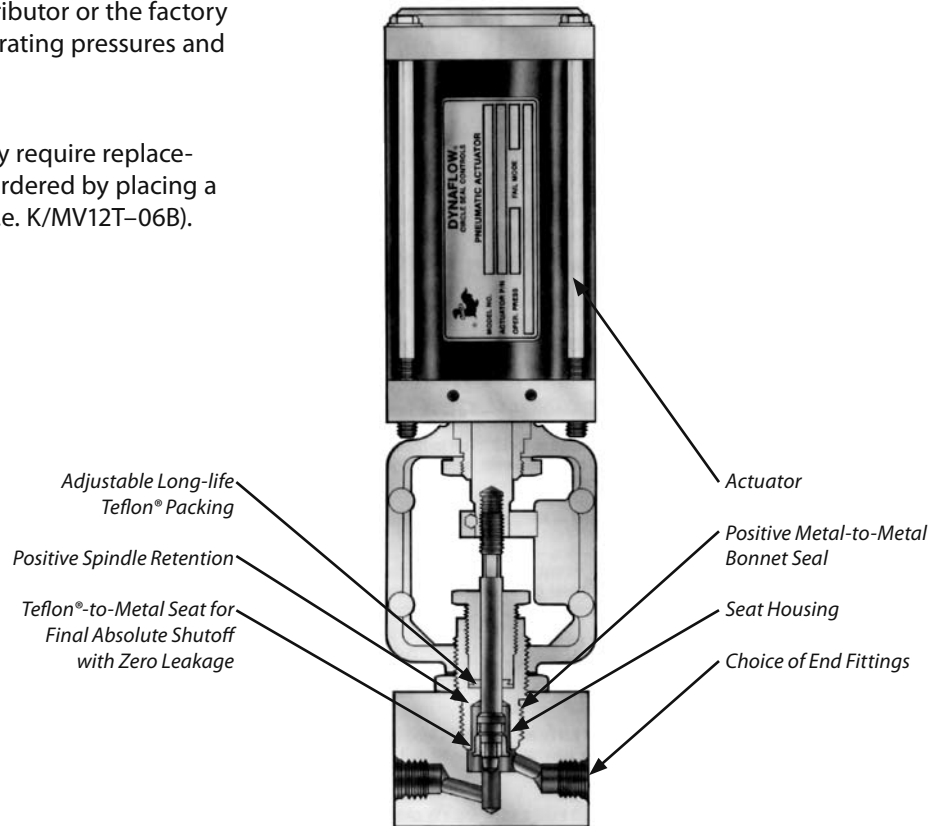

## For Your Safety

It is solely the responsibility of the system designer and user to select products suitable for their specific application requirements and to ensure proper installation, operation, and maintenance of these products. Material compatibility, product ratings and application details should be considered in the selection. Improper selection or use of products described herein can cause personal injury or property damage.

DYNAFLOW® is a registered trademark of Circle Seal Controls.

Teflon® is a registered trademark of the DuPont Company.

Aminco™ is a trademark of American Instrument Company.